

**THOR**  
K I T C H E N<sup>®</sup>

**Thor Kitchen Product Line  
2019**



**Model# HRG3080U**

## Thor Kitchen 30 inch Professional Gas Range



### DIMENSION & WEIGHT

#### Product Dimension

Product width	29 7/8"
Product height (from bottom to top of back splash)	37 1/6"
Product height (from bottom to top of side panel)	35 1/3"
Product depth (from back panel to bullnose including gasket)	28 1/4"
Product depth (from back panel to control board including gasket)	26 5/6"
Product depth (from back panel to side panel front including gasket)	24 3/5"
Depth of control panel (minimum)	3 2/3"
Depth of control panel (bullnose)	1 2/5"
Cast iron cooking grate (W x L)	21 6/7" x 11 1/35"
Adjustable legs	Recommend not to exceed 1/2"
Power plug length	56 1/4"
<b>Required Cutout Size (W x D x H) (in)</b>	<b>32 1/2" x 29 1/2" x 44 3/5"</b>

### FEATURES

- Black Porcelain Drip Pan On Cook Top
- Heavy Duty Continuous Cast Iron Cooking Grates
- Automatic Re-Ignition Safety Feature
- Blue LED Light up the knobs
- Zinc Alloy black Controller Knobs
- Heavy Duty handle with Zinc Alloy holder
- Stainless-Steel Professional look and stronger construction
- Blue porcelain oven interior
- 2 x Halogen Lights
- Commercial convection fan

### BURNER PERFORMANCE

Total Number of Range Top Burners	4 Burners
Front Right (Dual Burner with simmer function)	15,000 BTU (650 BTU for Simmer)
Front Left (Single)	18,000 BTU
Rear Right (Single)	12,000 BTU
Rear Left (Single)	12,000 BTU
Tube Broil burner	13,000 BTU
U-shape Bake burner	22,000 BTU

### TECHNICAL DETAILS

Fuel Type	Natural Gas / LP Convertible
Electrical Requirements	120V
Circuit Breaker (A)	15 or 20 A
Frequency (Hz)	60 Hz

### ACCESSORIES (NOT INCLUDED)

Liquid propane Gas Conversion Kit

### WARRANTY

2 Year Warranty On Parts and Labor

# Model# HRG3618U

## Thor Kitchen 36 inch Professional Gas Range



### DIMENSION & WEIGHT

#### Product Dimension

Product width	35 7/8"
Product height (from bottom to top of back splash)	37 1/6"
Product height (from bottom to top of side panel)	35 1/3"
Product depth (from back panel to bullnose including gasket)	28 1/4"
Product depth (from back panel to control board including gasket)	26 5/6"
Product depth (from back panel to side panel front including gasket)	24 3/5"
Depth of control panel (minimum)	3 2/3"
Depth of control panel (bullnose)	1 2/5"
Cast iron cooking grate (W x L)	21 6/7" x 11 1/35"
Adjustable legs	Recommend not to exceed 1/2"
Power plug length	56 1/4"
<b>Required Cutout Size (W x D x H) (in)</b>	<b>39" x 30" x 44 3/5"</b>

### FEATURES

- Black Porcelain Drip Pan On Cook Top
- Heavy Duty Continuous Cast Iron Cooking Grates
- Automatic Re-Ignition Safety Feature
- Blue LED Light up the knobs
- Zinc Alloy black Controller Knobs
- Heavy Duty handle with Zinc Alloy holder
- Stainless-Steel Professional look and stronger construction
- Blue porcelain oven interior
- 2 x Halogen Lights
- Commercial convection fan

### BURNER PERFORMANCE

Total Number of Range Top Burners	6 Burners
Front Right (Dual Burner with simmer function)	15,000 BTU (650 BTU for Simmer)
Front Left (Dual Burner with simmer function)	15,000 BTU (650 BTU for Simmer)
Front Middle (Single)	18,000 BTU
Rear Right (Single)	12,000 BTU
Rear Left (Single)	12,000 BTU
Rear Middle (Single)	12,000 BTU
Infrared Broil burner	16,500 BTU
U-shape Bake burner	22,000 BTU

### TECHNICAL DETAILS

Fuel Type	Natural Gas / LP Convertible
Electrical Requirements	120V
Circuit Breaker (A)	15 or 20 A
Frequency (Hz)	60 Hz

### ACCESSORIES (NOT INCLUDED)

Liquid propane Gas Conversion Kit

### WARRANTY

2 Year Warranty On Parts and Labor

# Model# HRG4808U

## Thor Kitchen 48 inch Professional Gas Range



### DIMENSION & WEIGHT

#### Product Dimension

Product width	47 4/19"
Product height (from bottom to top of back splash)	37 1/6"
Product height (from bottom to top of side panel)	35 1/3"
Product depth (from back panel to bullnose including gasket)	28 1/4"
Product depth (from back panel to control board including gasket)	26 5/6"
Product depth (from back panel to side panel front including gasket)	24 3/5"
Depth of control panel (minimum)	3 2/3"
Depth of control panel (bullnose)	1 2/5"
Cast iron cooking grate (W x L)	21 6/7" x 11 1/35"
Adjustable legs	Recommend not to exceed 1/2"
Power plug length	56 1/4"
<b>Required Cutout Size (W x D x H) (in)</b>	<b>50 2/5" x 29 1/2" x 45 1/3"</b>

### FEATURES

- Black Porcelain Drip Pan On Cook Top
- Heavy Duty Continuous Cast Iron Cooking Grates
- Automatic Re-Ignition Safety Feature
- Blue LED Light up the knobs
- Zinc Alloy black Controller Knobs
- Heavy Duty handle with Zinc Alloy holder
- Stainless-Steel Professional look and stronger construction
- Blue porcelain oven interior
- 2 x Halogen Lights
- Commercial convection fan

### BURNER PERFORMANCE

Total Number of Range Top Burners	6 Burners
Front Right (Dual)	18,000 BTU
Front Left (Dual)	18,000 BTU
Front Middle (Single)	18,000 BTU
Rear Right (Dual Burner with simmer function)	15,000 BTU (650 BTU for Simmer)
Rear Left (Dual Burner with simmer function)	15,000 BTU (650 BTU for Simmer)
Rear Middle (Dual Burner with simmer function)	15,000 BTU (650 BTU for Simmer)
Griddle Burner	15,000 BTU
Infrared Broil burner	16,500 BTU
U-shape Bake burner	22,000 BTU
Tube Bake burner (18-inch oven)	14,000 BTU

### TECHNICAL DETAILS

Fuel Type	Natural Gas / LP Convertible
Electrical Requirements	120V
Circuit Breaker (A)	15 or 20 A
Frequency (Hz)	60 Hz

### ACCESSORIES (NOT INCLUDED)

Liquid propane Gas Conversion Kit

### WARRANTY

2 Year Warranty On Parts and Labor

**Model# HRD3088U**

## Thor Kitchen 30 inch Professional Dual Fuel Range



### DIMENSION & WEIGHT

#### Product Dimension

Product width	29 7/8"
Product height (from bottom to top of back splash)	37 1/6"
Product height (from bottom to top of side panel)	35 1/3"
Product depth (from back panel to bullnose including gasket)	28 1/4"
Product depth (from back panel to control board including gasket)	26 5/6"
Product depth (from back panel to side panel front including gasket)	24 3/5"
Depth of control panel (minimum)	3 2/3"
Depth of control panel (bullnose)	1 2/5"
Cast iron cooking grate (W x L)	21 6/7" x 11 1/35"
Adjustable legs	Recommend not to exceed 1/2"
Power plug length	56 1/4"
<b>Required Cutout Size (W x D x H) (in)</b>	<b>32 1/2" x 29 1/2" x 44 3/5"</b>

### FEATURES

- Black Porcelain Drip Pan On Cook Top
- Heavy Duty Continuous Cast Iron Cooking Grates
- Automatic Re-Ignition Safety Feature
- Blue LED Light up the knobs
- Zinc Alloy black Controller Knobs
- Heavy Duty handle with Zinc Alloy holder
- Stainless-Steel Professional look and stronger construction
- Blue porcelain oven interior
- 2 x Halogen Lights
- Commercial convection fan

### BURNER PERFORMANCE

Total Number of Range Top Burners	4 Burners
Front Right (Dual Burner with simmer function)	15,000 BTU (650 BTU for Simmer)
Front Left (Single)	18,000 BTU
Rear Right (Single)	12,000 BTU
Rear Left (Single)	12,000 BTU

### OVEN PERFORMANCE

Oven Capacity	4.2 cu. Ft
Bake Power	850 W (Top) / 3,000 W (Bottom)
Broil Power	3,500 W

### TECHNICAL DETAILS

Fuel Type	Natural Gas / LP Convertible
Electrical Requirements	240V, 4-Prong 14-50R Power Outlet
Circuit Breaker (A)	30A
Frequency (Hz)	60 Hz

### ACCESSORIES (NOT INCLUDED)

Liquid propane Gas Conversion Kit

### WARRANTY

2 Year Warranty On Parts and Labor



# Model# **HRD3606U**

## Thor Kitchen 36 inch Professional Dual Fuel Range



### DIMENSION & WEIGHT

#### Product Dimension

Product width	35 7/8"
Product height (from bottom to top of back splash)	37 1/6"
Product height (from bottom to top of side panel)	35 1/3"
Product depth (from back panel to bullnose including gasket)	28 1/4"
Product depth (from back panel to control board including gasket)	26 5/6"
Product depth (from back panel to side panel front including gasket)	24 3/5"
Depth of control panel (minimum)	3 2/3"
Depth of control panel (bullnose)	1 2/5"
Cast iron cooking grate (W x L)	21 6/7" x 11 1/35"
Adjustable legs	Recommend not to exceed 1/2"
Power plug length	56 1/4"
Required Cutout Size (W x D x H) (in)	39" x 30" x 44 3/5"

### FEATURES

- Black Porcelain Drip Pan On Cook Top
- Heavy Duty Continuous Cast Iron Cooking Grates
- Automatic Re-Ignition Safety Feature
- Blue LED Light up the knobs
- Zinc Alloy black Controller Knobs
- Heavy Duty handle with Zinc Alloy holder
- Stainless-Steel Professional look and stronger construction
- Blue porcelain oven interior
- 2 x Halogen Lights
- Commercial convection fan

### BURNER PERFORMANCE

Total Number of Range Top Burners	6 Burners
Front Right (Single)	18,000 BTU
Front Left (Single)	18,000 BTU
Front Middle (Single)	18,000 BTU
Rear Right (Dual Burner with simmer function)	15,000 BTU (650 BTU for Simmer)
Rear Left (Dual Burner with simmer function)	15,000 BTU (650 BTU for Simmer)
Rear Middle (Single)	12,000 BTU

### OVEN PERFORMANCE

Oven Capacity	5.2 cu. Ft
Bake Power	850 W (Top) / 3,000 W (Bottom)
Broil Power	3,500 W

### TECHNICAL DETAILS

Fuel Type	Natural Gas / LP Convertible
Electrical Requirements	240V, 4-Prong 14-50R Power Outlet
Circuit Breaker (A)	30A
Frequency (Hz)	60 Hz

### ACCESSORIES (NOT INCLUDED)

Liquid propane Gas Conversion Kit

### WARRANTY

2 Year Warranty On Parts and Labor

# Model# **HRD4803U**

## Thor Kitchen 48 inch Professional Dual Fuel Range



### DIMENSION & WEIGHT

Product Dimension		
Product width		47 4/19"
Product height (from bottom to top of back splash)		37 1/6"
Product height (from bottom to top of side panel)		35 1/3"
Product depth (from back panel to bullnose including gasket)		28 1/4"
Product depth (from back panel to control board including gasket)		26 5/6"
Product depth (from back panel to side panel front including gasket)		24 3/5"
Depth of control panel (minimum)		3 2/3"
Depth of control panel (bullnose)		1 2/5"
Cast iron cooking grate (W x L)		21 6/7" x 11 1/35"
Adjustable legs	Recommend not to exceed	1/2"
Power plug length		56 1/4"
Required Cutout Size (W x D x H) (in)		50 2/5" x 29 1/2" x 45 1/3"

### FEATURES

- Black Porcelain Drip Pan On Cook Top
- Heavy Duty Continuous Cast Iron Cooking Grates
- Automatic Re-Ignition Safety Feature
- Blue LED Light up the knobs
- Zinc Alloy black Controller Knobs
- Heavy Duty handle with Zinc Alloy holder
- Stainless-Steel Professional look and stronger construction

### Blue porcelain oven interior

- 2 x Halogen Lights
- Commercial convection fan

### BURNER PERFORMANCE

Total Number of Range Top Burners	6 Burners
Front Right (Single)	18,000 BTU
Front Left (Single)	18,000 BTU
Front Middle (Single)	18,000 BTU
Rear Right (Dual Burner with simmer function)	15,000 BTU (650 BTU for Simmer)
Rear Left (Dual Burner with simmer function)	15,000 BTU (650 BTU for Simmer)
Rear Middle (Dual Burner with simmer function)	15,000 BTU (650 BTU for Simmer)
Stainless Steel Griddle	15,000 BTU

### OVEN AND PERFORMANCE

Oven Capacity	6.7 cu. Ft. (4.2 cu. Ft. for 30-inch oven) (2.5 cu. Ft. for 18-inch oven)
Bake Power (30-inch oven)	850 W (Top) / 3,000 W (Bottom)
Bake Power (18-inch oven)	2,500 W (Bottom)
Broil Power (30-inch oven)	3,500 W

### TECHNICAL DETAILS

Fuel Type	Natural Gas / LP Convertible
Electrical Requirements	240V, 4-Prong 14-50R Power Outlet
Circuit Breaker (A)	40A
Frequency (Hz)	60 Hz

### ACCESSORIES (NOT INCLUDED)

Liquid propane Gas Conversion Kit

### WARRANTY

2 Year Warranty On Parts and Labor

# Model# **LRG3001U**

## Thor Kitchen - 30 inch Professional Gas Range



### DIMENSION & WEIGHT

#### Product Dimension

Product width	29.875"
Product height (from bottom to top of back splash)	36.7"
Product height (from bottom to top of side panel)	33.9"
Product depth (from back panel to bullnose including gasket)	28.3"
Product depth (from back panel to control board including gasket)	27.1"
Product depth (from back panel to side panel front including gasket)	24.8"
Depth of control panel (minimum)	2.3"
Depth of control panel (bullnose)	3.5"
Cast iron cooking grate (W x L)	21.2*11.8"
Adjustable legs	Recommend not to exceed 1"
Power plug length	56 1/4"
<b>Required Cutout Size (W x D x H) (in)</b>	<b>30.3" x 27.4" x 36.7"</b>

### FEATURES

- Black Porcelain Drip Pan for easy surface cleaning
- Heavy Duty Continuous Cast Iron Cooking Grates
- Black ABS Knobs
- 6.0 cu.ft. Oven Capacity
- White Flakes with Gray Background Porcelain Oven Interior
- 1 x Halogen Lights
- Commercial Convection Fan
- Three layers glass window
- Storage drawer at bottom

### BURNER PERFORMANCE

Total Number of Range Top Burners	5 Burners
Front Right (Single)	8,000 BTU
Front Left (Single)	18,000 BTU
Middle (Oval)	9,000 BTU
Rear Right (Single)	6,000 BTU
Rear Left (Single)	4,000 BTU
Tube Broil burner	10,000 BTU
U-shape burner (30" Oven)	18,500 BTU

### TECHNICAL DETAILS

Fuel Type	Natural Gas / LP Convertible
Electrical Requirements	120V
Circuit Breaker (A)	15 or 20 A
Frequency (Hz)	60 Hz

### ACCESSORIES (NOT INCLUDED)

Liquid propane Gas Conversion Kit

### WARRANTY

2 Year Warranty On Parts and Labor



# Model# **LRG3601U**

## Thor Kitchen - 36 inch Professional Gas Range



### Product Dimension

Product width	36 in
Product height (from bottom to top of island trim)	36 7/8 in
Product height (from bottom to top of drip pan)	35 1/2 in
Product height (from bottom to top of bullnose)	36 1/8 in
Product depth (without door)	24 in
Product Depth (including door)	26 7/16 in
Product depth (including control board)	26 5/16 in
Product depth (including bullnose)	27 1/2 in
Product Depth (including door handle)	29 1/2 in
Product depth (with door fully-open)	48 1/8 in
Oven Interior Dimension	28 3/4W x 17 1/4D x 17 H in
Oven door window	28 in
Adjustable legs	Recommend no more than 1"
Power plug length	56 1/4"
<b>Required Cutout Size (W x D x H) (in)</b>	<b>36 1/4W x 24 1/2 D x 35 1/2 H</b>

### FEATURES

- Black Porcelain Drip Pan for easy surface cleaning
- Heavy Duty Continuous Cast Iron Cooking Grates
- Black ABS Knobs
- 6.0 cu.ft Oven Capacity
- White Flakes with Gray Background Porcelain Oven Interior
- 1 x Halogen Lights
- Commercial Convection Fan
- Three layers glass window
- Storage drawer at bottom

### BURNER PERFORMANCE

Total Number of Range Top Burners	6 Burners
Front Right (Single)	18,000 BTU
Front Left (Single)	18,000 BTU
Front Middle (Single)	12,000 BTU
Rear Right (Single)	9,000 BTU
Rear Left (Single)	9,000 BTU
Rear Middle (Single)	12,000 BTU
Tube Broil burner	10,000 BTU
U-shape burner (30" Oven)	18,500 BTU

### TECHNICAL DETAILS

Fuel Type	Natural Gas / LP Convertible
Electrical Requirements	120V
Circuit Breaker (A)	15 or 20 A
Frequency (Hz)	60 Hz

### ACCESSORIES (NOT INCLUDED)

Liquid propane Gas Conversion Kit

### WARRANTY

2 Year Warranty On Parts and Labor

**Model# LRG4801U**  
**Thor Kitchen - 48 inch Professional Gas Range**



**DIMENSION & WEIGHT**

<b>Product Dimension</b>		
Product width		47.875"
Product height (from bottom to top of back splash)		37.2"
Product height (from bottom to top of side panel)		34.9"
Product depth (from back panel to bullnose including gasket)		27.4"
Product depth (from back panel to control board including gasket)		27.1"
Product depth (from back panel to side panel front including gasket)		24.8"
Depth of control panel (minimum)		2.3"
Depth of control panel (bullnose)		3.5"
Cast iron cooking grate (W x L)		21.85*11"
Adjustable legs	Recommend not to exceed	1"
Power plug length		56 1/4"
<b>Required Cutout Size (W x D x H) (in)</b>		<b>48.2" x 27.2" x 36"</b>

**FEATURES**

- Black Porcelain Drip Pan for easy surface cleaning
- Heavy Duty Continuous Cast Iron Cooking Grates
- Automatic Re-Ignition Safety Feature
- Black ABS Knobs
- 30" Oven
- 4.6 cu.ft. Oven Capacity ,White flakes with Grey background Porcelain Oven Interior
- 2 x Halogen Lights
- Commercial Convection Fan
- 18" Oven
- 2.2 cu.ft. Oven Capacity
- White flakes with Grey background Porcelain Oven Interior
- 1 x Halogen Light

**BURNER PERFORMANCE**

Total Number of Range Top Burners	6 Burners
Front Right (Single)	18,000 BTU
Front Left (Single)	18,000 BTU
Front Middle (Single)	12,000 BTU
Rear Right (Single)	9,000 BTU
Rear Left (Single)	9,000 BTU
Rear Middle (Single)	12,000 BTU
Griddle Burner	15,000 BTU
Tube Broil burner	10,000 BTU
U-shape burner (30" Oven)	22,000 BTU
Tube burner (18" Oven)	14,000BTU

**TECHNICAL DETAILS**

Fuel Type	Natural Gas / LP Convertible
Electrical Requirements	120V
Circuit Breaker (A)	15 or 20 A
Frequency (Hz)	60 Hz

**ACCESSORIES (NOT INCLUDED)**

Liquid propane Gas Conversion Kit

**WARRANTY**

2 Year Warranty On Parts and Labor

**Model# HRT3003U**

## Thor Kitchen 30 inch Professional Range Top



### FEATURES

- Black Porcelain Drip Pan On Cook Top
- Heavy Duty Continuous Cast Iron Cooking Grates
- Automatic Re-Ignition Safety Feature
- Blue LED Control Panel Light
- Zinc Alloy Controller Knobs
- 304 Stainless Steel Control Panel

### BURNER PERFORMANCE

Total Number of Range Top Burners	4 Burners
Front Right (Single)	18,000 BTU
Front Left (Single)	18,000 BTU
Rear Right (Single)	12,000 BTU
Rear Left (Dual burner with simmer function)	15,000 BTU (650 BTU for Simmer)

### TECHNICAL DETAILS

Fuel Type	Natural Gas / LP Convertible
Electrical Requirements	120V
Circuit Breaker (A)	15 or 20 A
Frequency (Hz)	60 Hz

### DIMENSION & WEIGHT

Product Dimension (W x D x H) (in)	30" W x 27 1/2" D x 9 1/4" H
Required Cutout Size (W x D x H) (in)	30 1/4" x 24" x 7 5/8" - 7 7/8"
Product Net Weight	70 lbs.
Adjustable Range Legs	1/2"
Package Dimension:	33" L x 30" W x 13 3/8" H

### ACCESSORIES (NOT INCLUDED)

Liquid propane Gas Conversion Kit

### WARRANTY

2 Year Warranty On Parts and Labor

**Model# HRT3618U**

## Thor Kitchen 36 inch Professional Range Top



### FEATURES

Black Porcelain Drip Pan On Cook Top  
Heavy Duty Continuous Cast Iron Cooking Grates  
Automatic Re-Ignition Safety Feature  
Blue LED Control Panel Light  
Zinc Alloy Controller Knobs  
304 Stainless Steel Control Panel

### BURNER PERFORMANCE

Total Number of Range Top Burners	6 Burners
Front Right (Single)	18,000 BTU
Front Middle (Dual burner with simmer function)	15,000 BTU (650 BTU for Simmer)
Front Left (Single)	18,000 BTU
3 Rear Burners (Single)	12,000 BTU

### TECHNICAL DETAILS

Fuel Type	Natural Gas / LP Convertible
Electrical Requirements	120V
Circuit Breaker (A)	15 or 20 A
Frequency (Hz)	60 Hz

### DIMENSION & WEIGHT

Product Dimension (W x D x H) (in)	36" W x 27 1/2" D x 9 1/4" H
Required Cutout Size (W x D x H) (in)	36 1/4" x 24" x 7 5/8"-7 7/8"
Product Net Weight	90 lbs.
Adjustable Range Legs	1/2"
Package Dimension:	39"L x 30" W x 13 3/8" H

### ACCESSORIES (NOT INCLUDED)

Liquid propane Gas Conversion Kit

### WARRANTY

2 Year Warranty On Parts and Labor

**Model# HRT4806U**

## Thor Kitchen 48 inch Professional Range Top



### FEATURES

- Black Porcelain Drip Pan On Cook Top
- Heavy Duty Continuous Cast Iron Cooking Grates
- Automatic Re-Ignition Safety Feature
- Blue LED Control Panel Light
- Zinc Alloy Controller Knobs
- 304 Stainless Steel Control Panel

### BURNER PERFORMANCE

Total Number of Range Top Burners	6 Burners
3 Front Burners (Single)	18,000 BTU
3 Rear Burners (Dual burner with simmer function)	15,000 BTU (650 BTU for Simmer)
Stainless Steel Griddle	15,000 BTU

### TECHNICAL DETAILS

Fuel Type	Natural Gas / LP Convertible
Electrical Requirements	120V
Circuit Breaker (A)	15 or 20 A
Frequency (Hz)	60 Hz

### DIMENSION

Product Dimension (W x D x H) (in)	48" W x 27 1/2" D x 9 1/4" H
Required Cutout Size (W x D x H) (in)	48 1/4" x 24" x 7 5/8" - 7 7/8"
Adjustable Range Legs	1/2"

### ACCESSORIES (NOT INCLUDED)

- Liquid propane Gas Conversion Kit

### WARRANTY

- 2 Year Warranty On Parts and Labor



## Model#

**HRH3006U/ HRH3606U/ HRH4806U**

## (06 SERIES RANGE HOOD)

THOR Kitchen Under Cabinet Canopy Pro Style  
Range Hood in Stainless Steel with Anti-Fingerprint Finish  
(30" / 36" / 48")



### FEATURES

<b>Controls</b>	3 Speed Fan Touch Control Buttons		
<b>Installation Type</b>	Ducted (Top)		
<b>Illumination</b>	<b>30" / 36"</b>	Two (2) 1.5W LED Light	
	<b>48"</b>	Three (3) 1.5W Long Life LED Light	
<b>Blower</b>	<b>30" / 36"</b>	900 CFM	One (1) 6 7/8" Round Duct
	<b>48"</b>	900 CFM	One (2) 6 7/8" Round Duct
<b>Filter Type</b>	Baffle Filters / Stainless Steel / Dishwasher Safe		
<b>Special Function</b>	15 Minutes Pre-Programmed Auto Shut-Off		

### SPECIFICATION

<b>Size</b>	30", 36", 48"		
<b>Models</b>	<b>HRH3006U</b>	29 3/4"(W) x 21 5/8"(D) x 9 7/8"(H)	
	<b>HRH3606U</b>	35 3/4"(W) x 21 5/8"(D) x 9 7/8"(H)	
	<b>HRH4806U</b>	47 3/4"(W) x 21 5/8"(D) x 9 7/8"(H)	
<b>Type / Finish</b>	Under Cabinet Range Hood / Stainless Steel		
	Anti-Fingerprint with Luster		
<b>Electrical</b>	15 Amps at 120 Volts		
<b>Certification</b>	CSA Certified		

# Model# **HRH3007**

**Product Description: 30-in Wall Mount Chimney Range Hood in Stainless Steel with LED Lights, Touch Control with Display and Remote Control**

**THOR**  
K I T C H E N<sup>®</sup>



**Replacement Model for HRH3004U**

Range Hood Size	<b>30in</b>	Appliance Type	<b>Wall Mount / touch control with display</b>
Product Width(in)	<b>30in</b>	CFM	<b>600</b>
Product Depth(in)	<b>19in</b>	Voltage	<b>120V</b>
Product Height(in)	<b>11 7/8" (without duct covers) 45.5" (including duct covers)</b>	Wattage	<b>337W</b>
Duct Length(in)	<b>34 in</b>	Color/Finish	<b>Stainless steel</b>
Duct Width(in)	<b>Diameter:6in</b>	Certifications	<b>ETL</b>
Duct Shape	<b>Round</b>	UPC #	<b>6926697001233</b>
Amperage	<b>/</b>	Filter type	<b>430SS Baffle filter</b>
Gross Weight (lbs.)	<b>38.4</b>	Blower type	<b>/</b>
Net Weight (lbs.)	<b>28.3</b>	Control type	<b>Remote control</b>
Fan Speeds	<b>3 speed</b>	Ceiling Height (Min.)	<b>8 feet</b>
Noise level (Max.)	<b>60 dB</b>	Installation type	<b>Wall mount</b>
Lighting	<b>Dual 3.5W GU10 LED light</b>	Power	<b>/</b>

# Model# **HRH3007**

**Product Description: 30-in Wall Mount Chimney Range Hood in Stainless Steel with LED Lights, Touch Control with Display and Remote Control**

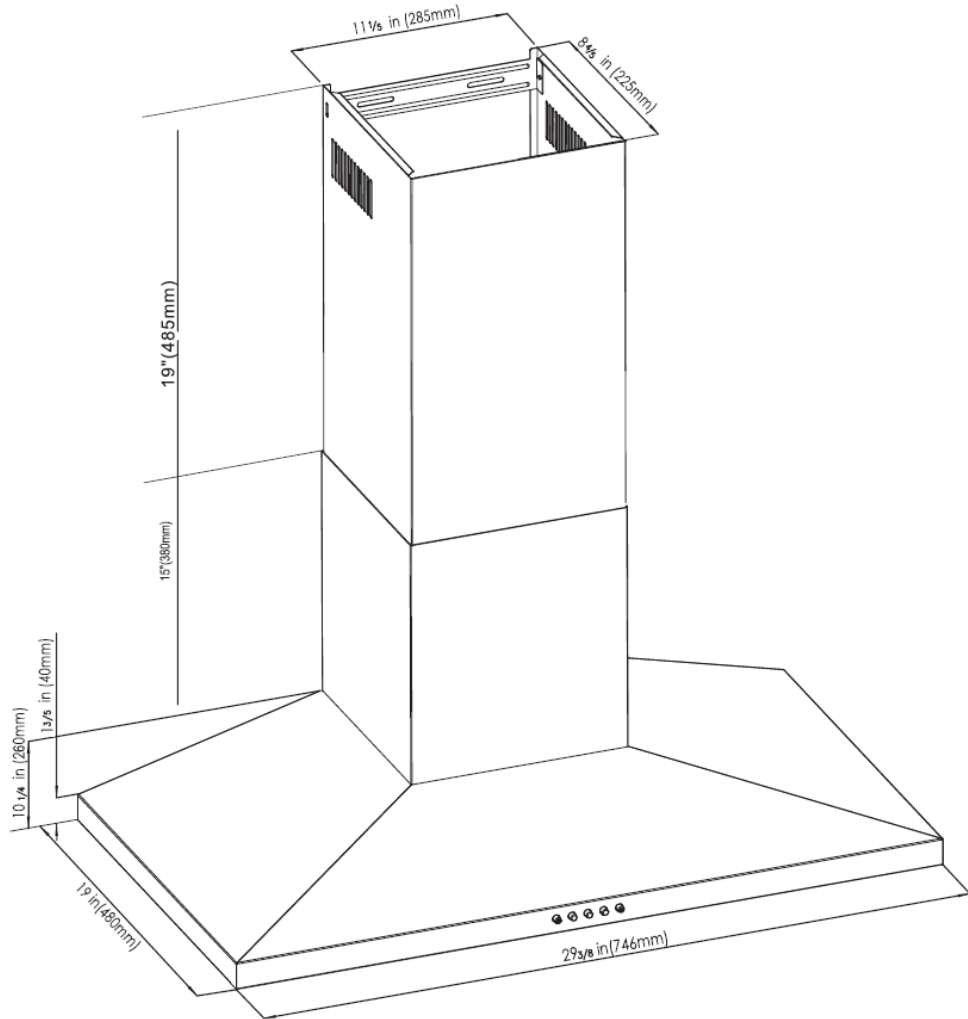

Duct size	<b>Diameter: 6 in</b>	Loading Information	<b>40'HQ: 310 pcs</b>
Duct Discharge	/	Features	<ul style="list-style-type: none"> <li>- Wall mount design</li> <li>- Touch control with display</li> <li>- 3 speed with Max. 600CFM</li> <li>- Clean canopy design</li> <li>- Durable brushed stainless steel</li> <li>- Easy lamp replacement without tools</li> <li>- Extension chimney included</li> <li>- Dual 3.5W GU10 LED light</li> <li>- Large, full 430SS baffle filter</li> <li>- Remote control</li> <li>- Clock shown, delay off, filter clean reminder</li> </ul> <p><b>Vertical vent diameter 6" round</b></p>
Hood Cover size	/		
Ceiling Height (Max)	<b>9 feet</b>		
Frequency	<b>60HZ</b>		

# Model# **HRH3607**

**Product Description: 36-in Wall Mount Chimney Range Hood in Stainless Steel with LED Lights, Touch Control with Display and Remote Control**

**THOR**  
K I T C H E N<sup>®</sup>



**Replacement Model for HRH3604U**

Range Hood Size	<b>36in</b>	Appliance Type	<b>Wall Mount、Touch control with display</b>
Product Width(in)	<b>36in</b>	CFM	<b>600</b>
Product Depth(in)	<b>19in</b>	Voltage	<b>120V</b>
Product Height(in)	<b>11 7/8" (without duct covers) 45.5" (including duct covers)</b>	Wattage	<b>337W</b>
Duct Length(in)	<b>34 in</b>	Color/Finish	<b>Stainless steel</b>
Duct Width(in)	<b>Diameter:6 in</b>	Certifications	<b>ETL</b>
Duct Shape	<b>Round</b>	UPC #	<b>6926697011119</b>
Amperage	<b>/</b>	Filter type	<b>430SS Baffle filter</b>
Gross Weight (lbs.)	<b>41.8</b>	Noise level (Max.)	<b>60 dB</b>
Net Weight (lbs.)	<b>30.2</b>	Control type	<b>Remote control</b>
Fan Speeds	<b>3 speed</b>	Ceiling Height (Min.)	<b>8 feet</b>
Lighting	<b>Dual 3.5W GU10 LED light</b>	Installation type	<b>Wall mounted</b>

# Model# **HRH3607**

**Product Description: 36-in Wall Mount Chimney Range Hood in Stainless Steel with LED Lights, Touch Control with Display and Remote Control**

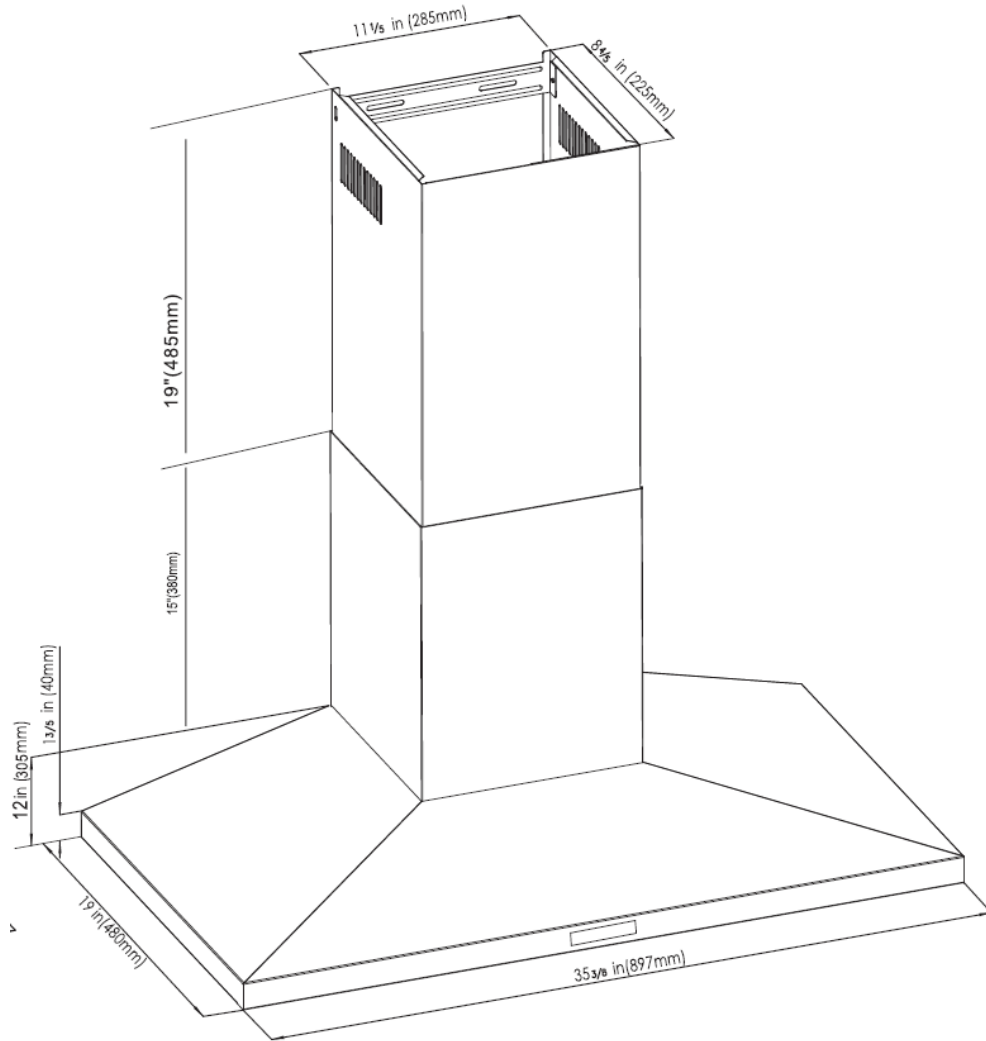

Duct size	<b>Diameter: 6in</b>	Loading Information	40'HQ: 260 pcs
Duct Discharge	/	Features	<ul style="list-style-type: none"> <li>- <b>Wall mount design</b></li> <li>- <b>Touch control with display</b></li> <li>- <b>Speed with Max.600CFM</b></li> <li>- <b>Clean canopy design</b></li> <li>- <b>Durable brushed stainless steel</b></li> <li>- <b>Easy lamp replacement without tools</b></li> <li>- <b>Extension chimney included</b></li> <li>- <b>Dual 3.5W GU10 LED light</b></li> <li>- <b>Large, full 430SS baffle filter</b></li> <li>- <b>Remote control</b></li> <li>- <b>Clock shown, delay off, filter clean reminder</b></li> <li>- <b>Vertical vent diameter 6" round</b></li> </ul>
Hood Cover size	/		
Ceiling Height (Max)	<b>9 feet</b>		
Frequency	<b>60HZ</b>		



Product Description: **Lycan - 30in Wall Mount Chimney Range Hood in Stainless Steel with Push Button**  
 Model # **LRH3001**



Range Hood Size	<b>30in</b>	Appliance Type	<b>Wall Mount</b>
Product Width(in)	<b>30in</b>	CFM	<b>400</b>
Product Depth(in)	<b>19in</b>	Voltage	<b>120V</b>
Product Height(in)	<b>43.5in</b>	Wattage	<b>220W</b>
Duct Length(in)	<b>59 in</b>	Color/Finish	<b>Stainless Steel</b>
Duct Width(in)	<b>Diameter:6in</b>	Certifications	<b>ETL</b>
Duct Shape	<b>Round</b>	UPC #	<b><u>6926697025611</u></b>
Amperage		Filter type	<b>430SS Baffle Filter</b>
Gross Weight(lbs.)	<b>31.3</b>	Duct size	<b>Diameter: 6in</b>
Net Weight(lbs.)	<b>25.6</b>	Control type	<b>Push Button</b>
Fan Speeds	<b>3 speed</b>	Ceiling Height (Min.)	<b>8 to 9 feet</b>
Noise level (Max.)	<b>58 dB</b>	Installation type	<b>Wall mount</b>
Lighting	<b>Dual 50W GU10 halogen light</b>	Frequency	<b>60HZ</b>



Model # **LRH3001**



Duct Discharge	<b>Diameter:6 inch</b>
Ceiling Height (Max)	<b>9 feet</b>
Shipping Dimension(in)	<b>32*14*22</b>
Features	<ul style="list-style-type: none"><li>• <b>Wall Mount Design</b></li><li>• <b>Push Button</b></li><li>• <b>3 speed</b></li><li>• <b>400 CFM airflow</b></li><li>• <b>Clean canopy design</b></li><li>• <b>Easy lamp replacement without tools</b></li><li>• <b>Durable brushed stainless steel</b></li><li>• <b>Extension chimney included</b></li><li>• <b>Dual 50W GU10 halogen light</b></li><li>• <b>Vertical vent 6" round</b></li><li>• <b>Outlet adapter included</b></li><li>• <b>Aluminum filter</b></li></ul>



## Model# **TBC2401DI**

**Product Description: 24-inch  
Indoor Dual Zone Beverage  
Center**



Wine Cooler Size	<b>24"</b>	Number of Shelves	<b>Left zone: 6pcs Right zone: 3pcs</b>
Product Width(in)	<b>23.43</b>	Wine Cooler Shelf Material	<b>Left zone: Beech wood Right zone: Metal with plastic dipping</b>
Product Depth(in)	<b>23.82</b>	Number of Doors	<b>2</b>
Product Height(in)	<b>34.25</b>	Temperature Range (F)	<b>Left zone: 41-65°F Right zone: 38-65°F</b>
Depth Excluding Handles(in)	<b>23.82</b>	Color/Finish	<b>Black housing and S.S. door trims</b>
Depth Including Handles	<b>25.39</b>	Type of Cooling Unit	<b>No Frost</b>
Depth without Door	<b>22.05</b>	Voltage(volts)	<b>110V-120V/60Hz</b>
Depth with Door Open 90 Degrees	<b>34.25</b>	Gross Weight(lbs.)	<b>142.85</b>
Height to Top of Door Hinge	<b>34.25</b>	Net Weight(lbs.)	<b>121.25</b>
Wine Cooler Type	<b>Built-in or Freestanding, indoor use</b>	Certifications	<b>ETL/CEC</b>
Adjustable Racks	<b>Only for right zone, 3 black wire shelves</b>	UPC #	<b><u>6926697044445</u></b>
Bottle Capacity	<b>21 bottle and 95 cans</b>	Shipping Dimension	<b>H39.69*W29.72*D30.16in</b>
Defrost Type	<b>Automatic</b>	Features	<b>See next page</b>



#### Features:

- 21 bottle for left zone and 95 can for right zone (5.24 cu.ft)
- Indoor use wine cooler
- Independent dual zone (**Left zone: 41-65°F, Right zone: 38-65°F**)
- Fan assisted cooling
- Seamless S.S door frame (45mm) with S.S. handle
- Non-reversible door
- Black painting exterior housing and rear plate
- S.S. vent kickplate
- 6pcs beech wood shelves with rolling slideways+3pcs wire shelves with wooden front
- LCD display with 2pcs **blue** lightings on top and 3pcs on each side
- Adjustable electronic touch control C° or F°
- Door opening alarm
- Temperature alarm
- Humidity display
- Activated charcoal filter (2pcs)
- Heating elements for winter function
- 4pcs adjustable feet
- Auto-defrost function with an interior circulating
- 2pcs evaporators for accurate temperature control
- Self contained condenser



**Model# TWC2401DO**  
**Product Description: 24-inch Outdoor Dual Zone Wine Cooler**



Wine Cooler Size	24"	Number of Shelves	5+1
Product Width(in)	23.43	Wine Cooler Shelf Material	Beech wood
Product Depth(in)	23.82	Number of Doors	1
Product Height(in)	34.25	Temperature Range (F)	41-64°F / 5-18°C
Depth Excluding Handles(in)	23.82	Color/Finish	S.S housing and S.S. door trims
Depth Including Handles	25.39	Type of Cooling Unit	No Frost
Depth without Door	22.05	Voltage(volts)	110V-120V/60Hz
Depth with Door Open 90 Degrees	46.06	Gross Weight (lb.)	152
Height to Top of Door Hinge	34.25	Net Weight (lb.)	130
Wine Cooler Type	Built-in or Freestanding, indoor or outdoor use	Certifications	Residential ETL/CEC
Adjustable Racks	No (with rolling slideways)	UPC #	<u>6926697022221</u>
Bottle Capacity	46	Shipping Dimension	H39.69*W29.72*D30.16in
Defrost Type	Automatic	Features	See next page





#### Features:

- 46 bottles capacity (5.43 cu.ft)
- Indoor or outdoor use wine cooler
- Thunder proof and water proof
- Independent dual zone (each zone reach 41°F - 64°F)
- Fan assisted cooling
- Seamless S.S door frame (60mm) with S.S. handle(304SS)
- SS Compressor Rear Cover (304SS)
- Dual pane of Low-E glass to filter UV rays**
- Reversible door (180° flip-over)
- S.S. exterior housing and rear plate (304SS)
- S.S. vent kickplate
- 5+1 beech wood rolling shelves with rolling slideways(Full Extension)
- LCD display with 2pcs **blue** lightings on top
- Adjustable electronic touch control C° or F°
- Door opening alarm
- Temperature alarm
- Activated charcoal filters (2pcs)
- Heating elements for winter function
- 4pcs adjustable feet
- 4pcs casters available for an additional cost
- No frost
- 2pcs evaporators for accurate temperature control
- Self contained condenser
- Refrigerant: R600a

# HWC2404U

## Product Description: 24-inch three zone built-in Wine Cooler



**THOR**  
K I T C H E N<sup>®</sup>

Wine Cooler Size	<b>Upper wine cooler: 10.6 cu. ft Bottom drawer: 9.9 cu. ft</b>	Wine Cooler Shelf Material	<b>Beech</b>
Product Width(in)	<b>29.5 "</b>	Number of Doors	<b>One of wine storage, Two doors of beer storage</b>
Product Depth(in)	<b>27"</b>	Temperature Range (F)	<b>Upper chamber: 46-55°F (8-13°C); Lower chamber:55-64°F (13-18°C); Bottom Drawer:34-46°F (1-8°C)</b>
Product Height(in)	<b>74"</b>	Color/Finish	<b>Black cabinet and stainless-steel door frame</b>
Depth Excluding Handles(in)	<b>27"</b>	Type of Cooling Unit	<b>Compressor and air-cooling style</b>
Depth Including Handles	<b>29"</b>	Voltage(volts)	<b>110-120V</b>
Depth without Door	<b>24.8"</b>	Gross Weight(lbs.)	<b>373 Lbs</b>
Depth with Door Open 90 Degrees	<b>55.1"</b>	Net Weight(lbs.)	<b>338 Lbs</b>
Height to Top of Door Hinge	<b>74"</b>	Certifications	<b>ETL</b>
Wine Cooler Type	<b>Built in or freestanding</b>	UPC #	<b>6926697011126</b>
Adjustable Racks	<b>Yes</b>		
Bottle Capacity	<b>128 wine bottles and 80 beer cans</b>	Features	<ul style="list-style-type: none"> <li>- <b>Adjustable handcrafted natural beech wooden shelves without chemical aromas influence to wines flavors and looks attractive</b></li> <li>- <b>Touch pad digital control with LED readout;</b></li> <li>- <b>No frost Design with interior circulating;</b></li> <li>- <b>LED interior lighting enhances visibility;</b></li> <li>- <b>Full extension drawer slides;</b></li> <li>- <b>304 stainless steel drawer interiors, ideal for food storage.</b></li> </ul>
Defrost Type	<b>Auto</b>		
Number of Doors	<b>One of wine storage, Two doors of beer storage</b>		
Number of Shelves	<b>9 Wood shelves</b>		

## Model# **HWC2405U**

### THOR Kitchen 18 inch 40 Bottle Single Zone Built-in/Freestanding Wine Cooler

#### Features

Type	Built-in installation or Freestanding
Temperature Zone	40-65°F
Capacity	40 Bottles (Standard Bordeaux 750 ml bottles / 2.75" in diameter)
Exterior Finish	Stainless Steel
Noise Level	41db
Cooling System	Compressor Powered Cooling No Frost Air Circulating Design
Lighting	White LED Interior Light
Door/Window	Double Tampered Glass Window with Stainless Steel Door Frame

#### Specification

Cirtifications	ETL, CSA, UL
Shelves	6 Wooden Shelves
Refrigerant	R600a
Rated Current Amps	1.4 A
Input power	100 W
Ambient Temperature	46-100°F
Rated Voltage/Frequency	115V/60Hz
Product Dimension	17.75 x 22.75 x 34.25 in. (W/D/H)
RoHS Compatible Unit	Energy Class: A, DOE



# Model# **HWC2408U**

## 24" Wide 133-Bottle Built-In Dual Zone Wine Cooler

### Features

Type	Built-in / Freestanding installation
Temperature Zone	Upper Zone 5-12°C / 41-54°F Lower Zone 12-18°C / 54-65°F
Capacity	Wine storage : 133 bottles / 380 L. (Standard Bordeaux 750 ml bottles / 2.75" in diameter)
Exterior Finish	Stainless steel trimmed glass door with tempered double pane smoked glass
Noise Level	45 db.
Cooling System	Compressor Powered Cooling No Frost Air Circulating Design
Lighting	White LED Interior Light / Blue LED Touch Control
Wine Rack	Wooden Racks With Ball Bearing Slides

### Specification

Certifications	ETL Certified
Shelves	13 Ball Bearing Sliding Wooden Shelves
Refrigerant	R600a
Input power	130 W / 1.8 Amps
Rated Voltage/Frequency	110V-120V/60Hz
Power Plug	65 inch
Product Width	23 ¾"
Product Depth	24 ⅞" (Exclude door) 26 ½" (with Door) 28 ¼" (with handle) 49" (with door open)
Product Height	62 ½" (exclude hinge) 62 ¾" (with hinge)



**Replacement Model  
for HWC2403U**

### Product Weight and Load QTY information

Product Net / Gross Weight	201 lbs. / 210 lbs.
UPC Code	6926697024089

# Model# **TWC2402**

24-inch 42 bottles wine cooler



Wine Cooler Size	<b>24-inch 42 bottles wine cooler</b>	Wine Cooler Shelf Material	<b>Metal wood</b>
Product Width(in)	<b>23 1/2"</b>	Number of Doors	<b>One door</b>
Product Depth(in)	<b>23"</b>	Temperature Range (F)	<b>41-68°F both two sides</b>
Product Height(in)	<b>34 1/4"</b>	Color/Finish	<b>Black cabinet and stainless steel door frame</b>
Depth Excluding Handles(in)	<b>23"</b>	Type of Cooling Unit	<b>Compressor and air cooling style</b>
Depth Including Handles	<b>26 1/8"</b>	Voltage(volts)	<b>110-120V</b>
Depth without Door	<b>21 1/2"</b>	Gross Weight(lbs.)	<b>108 Lbs</b>
Depth with Door Open 90 Degrees	<b>34"</b>	Net Weight(lbs.)	<b>99 Lbs</b>
Height to Top of Door Hinge	<b>34 1/4"</b>	Certifications	<b>ETL</b>
Wine Cooler Type	<b>Built- in or freestanding</b>	UPC #	<b>6926697057568</b>
Adjustable Racks	<b>Yes</b>	Features	<b>1.Seamless stainless steel door; 2.Touch pad digital control with LED readout; 3.Auto-defrost function with an interior circulating; 4.LED interior lighting</b>
Bottle Capacity	<b>42 wine bottles</b>		
Defrost Type	<b>Auto</b>		
Number of Doors	<b>Two door</b>		
Number of Shelves	<b>10 Metal shelves</b>		



# Model# **TWC24TBDI**

24-inch built-in Dual zone Wine Cooler



DESCRIPTION	HIGHLIGHTED SPECIFICATIONS	
24-inch 191 Bottle Professional Series Dual Zone Wine Cooler with Sabbath Mode	Dual Zone Temperatures	3-color LED Interior Lighting
	SS Door/Handle	Auto-Defrost Design
	Built-In or Freestanding	Seamless SS Double Pane Glass Door

# Model# **TWC1501**

15-inch 33 bottles wine cooler



Wine Cooler Size	<b>33 bottles wine cooler</b>	Wine Cooler Shelf Material	<b>Beech wood</b>
Product Width(in)	<b>15"</b>	Number of Doors	<b>One door</b>
Product Depth(in)	<b>22 13/16"</b>	Temperature Range (F)	<b>41-68°F</b>
Product Height(in)	<b>34 1/4"</b>	Color/Finish	<b>Black cabinet and stainless steel door frame</b>
Depth Excluding Handles(in)	<b>22 13/16"</b>	Type of Cooling Unit	<b>Compressor and air cooling style</b>
Depth Including Handles	<b>24 19/32"</b>	Voltage(volts)	<b>110-120V</b>
Depth without Door	<b>20 13/16"</b>	Gross Weight(lbs.)	<b>84 Lbs</b>
Depth with Door Open 90 Degrees	<b>36 19/32"</b>	Net Weight(lbs.)	<b>74 Lbs</b>
Height to Top of Door Hinge	<b>34 1/4"</b>	Certifications	<b>ETL</b>
Wine Cooler Type	<b>Built- in or freestanding</b>	UPC #	<b>6926697058923</b>
Adjustable Racks	<b>Yes</b>	Features	<b>1.Adjustable handcrafted natural beech wooden shelves without chemical aromas influence to wines flavors and looks attractive;</b> <b>2.Touch pad digital control with LED readout;</b> <b>3.No frost with an interior circulating;</b> <b>4.LED interior lighting;</b> <b>5.Security lock;</b> <b>6.Door open alarm;</b> <b>7. Sabbath Mode</b>
Bottle Capacity	<b>33 wine bottles</b>		
Defrost Type	<b>Auto</b>		
Number of Doors	<b>One door</b>		
Number of Shelves	<b>6 Wood shelves</b>		

# Model # HDW2401SS

24in Built-in Pro Style Dishwasher  
in Black Stainless Steel



## Features:

- Delayed Start (Pre-programmed 1 - 24 hrs)
- Multiple Filter System
- 45 dB Noise Level
- Smart Wash System
- 3 Spray Arms
- Removable Utensil Basket
- 3 racks
- Control-Lock (Same as child lock)

## Specification:

Size	24 inch built-In dishwasher
Depth with door open	50 inch
Product Weight	91lb (41kg)
Power Supply	120volts, 60Hz
Rated Power Usage	Wash motor 95W Heater 840W
Power of Heating Element	120V / 840W
Inlet Water Temperature Minimum	120°F (49°C)
Water Feed Pressure	20 ~ 120 psi (138~ 828kPa)
Water Consumption	3.5 gallons (by DOE)
System Outlet Hose Length	59"
Washing Performance	80 Plus Certified
Water Consumption	≤ 13.31L (3.1gal)
Energy Saving Class At A++	CSA Certificated

## Model # **HRF2401U**

### 24 in. 5.3 cu. ft. Double Drawer Under-Counter Refrigerator in Stainless Steel, Counter Depth

Specification	
Temperature Range	<b>32°F ~ 50°F</b>
Ambient Temperature	<b>Up to 109°F</b>
Lighting	<b>White LED Interior Lights</b>
Installation Type	<b>Built-In or Freestanding Installation</b>
Control	<b>Digital Control</b>
Cooling Type	<b>Ventilated cooling</b>
Features	<b>No Frost Design</b>
	<b>304 Stainless Steel Drawers</b> <b>Soft-closing drawers</b>
Certification	<b>ETL / CETL / DOE / ROHS</b>
Product Dimension	<b>23.6"W x 23.6"D x 34"H</b>
Cutout Requirement	<b>24"W x 22"D x 34.25"H</b>
Product Net Weight	<b>128 lbs.</b>



- **When using outdoor, this unit does not need additional parts/kit or leave extra space.**
- **Please make sure nothing covers the vent located at the front bottom of the refrigerator.**

# Model # **HRF3601F**

THOR Kitchen 36in Counter Depth French Door  
Freestanding Refrigerator with Automatic Ice Maker in  
Stainless Steel



## CAPACITY

Total Unit Gross Capacity	20.85 cu. ft.
Refrigerator Gross Capacity	15.16 cu. ft.
Freezer Gross Capacity	5.69 cu. ft.

## FEATURES

Counter Depth French Door  
2-Drawer Freezer  
Full-Width Chiller Drawer  
Retractable Shelf  
Dual Cycle and Dual Air-Cooled Refrigeration System  
2 Large Humidity Controlled Fresh Food Drawers  
Automatic Ice-Maker

## TECHNICAL DETAILS

Rated Current (A)	2.7 A
Defrost Current (A)	3.5 A
Volts (V)	115 V
Frequency (Hz)	60 Hz
Plug Type	120V-3 Prong
Refrigerant	R134a, 6.35 oz.

## REFRIGERATOR

Lighting	High-Efficiency LED
Number of Shelves - Refrigerator	5
Adjustable Shelves - Refrigerator	4 Half-Width
Shelf Material - Refrigerator	Tempered Glass
Type of Shelves - Refrigerator	Tempered Glass
Gallon Storage Bins	4
Humidity Control Drawer	2
Defrost Process Freezer	Automatic
Defrost Process Refrigerator	Frost-Free



**Model# HRF3602**

**Thor Kitchen - 22.5 cu. ft.  
4-Door French Door  
Refrigerator with Recessed  
Handle in Stainless Steel,  
Counter Depth**

Refrigerator Size	<b>36 inch</b>	Number of Doors	<b>4</b>
Product Width(in)	<b>35.8</b>	Number of Shelves	<b>6</b>
Product Depth(in)	<b>28.7</b>	Number of Freezer Baskets/Bins	<b>4</b>
Product Height(in)	<b>69.9</b>	Refrigerator Shelf Material	<b>Plastic</b>
Depth Excluding Handles(in)	<b>28.7</b>	Freezer Bin/Shelf Material	<b>Plastic</b>
Depth Including Handles	<b>No Handle</b>	Color/Finish	<b>Stainless Steel</b>
Depth without Door	<b>24.4in</b>	Gross Weight(lbs.)	<b>297.6</b>
Depth with Door Open 90 Degrees	<b>43.15in</b>	Net Weight(lbs.)	<b>284.4</b>
Height to Top of Door Hinge	<b>69.80in</b>	Certifications	<b>UL</b>
Height to Top of Refrigerator	<b>68.70in</b>	UPC #	<b>6926697052037</b>
Refrigerator Type	<b>French Door Refrigerator</b>		
Refrigerator Capacity	<b>16 cu. ft</b>	Refrigerator Features	<b>Adjusts for Bottle Size,Counter Depth,Door Alarm,Interior Light,LED Light Type,Refrigerator Light</b>
Freezer Capacity	<b>6.5 cu. ft</b>	Freezer Features	<b>Adjustable Temperature Control Ice Maker 24.4 inch width 6 gallon bottle frames silver interior</b>

Counter Depth	<b>Yes</b>	Water Dispenser	<b>No</b>
Shelf material	<b>glass+stainless</b>	Water Filter	<b>No</b>
Ice maker	<b>Automatic</b>	Loading Information (20' / 40' / 40HQ)	<b>18/36/48</b>





Model# **HRF3602BS**

Thor Kitchen 22.5 cu. ft. 4-Door French Door Refrigerator with Recessed Handle in Black Stainless Steel, Counter Depth

Counter Depth	<b>Yes</b>	Water Dispenser	<b>No</b>
Shelf material	<b>glass+stainless</b>	Water Filter	<b>No</b>
Ice maker	<b>Automatic</b>	Loading Information (20' / 40' / 40HQ)	<b>18/36/48</b>

Refrigerator Size	<b>36 inch</b>	Number of Doors	<b>4</b>
Product Width(in)	<b>35.8</b>	Number of Shelves	<b>6</b>
Product Depth(in)	<b>28.7</b>	Number of Freezer Baskets/Bins	<b>4</b>
Product Height(in)	<b>69.9</b>	Refrigerator Shelf Material	<b>Plastic</b>
Depth Excluding Handles(in)	<b>28.7</b>	Freezer Bin/Shelf Material	<b>Plastic</b>
Depth Including Handles	<b>No Handle</b>	Color/Finish	<b>Black Stainless</b>
Depth without Door	<b>24.4in</b>	Gross Weight(lbs.)	<b>297.6</b>
Depth with Door Open 90 Degrees	<b>43.15in</b>	Net Weight(lbs.)	<b>284.4</b>
Height to Top of Door Hinge	<b>69.80in</b>	Certifications	<b>UL</b>
Height to Top of Refrigerator	<b>68.70in</b>	UPC #	<b>BS:6926697058961</b>
Refrigerator Type	<b>French Door Refrigerator</b>		
Refrigerator Capacity	<b>16 cu.ft.</b>	Refrigerator Features	<b>Adjusts for Bottle Size,Counter Depth,Door Alarm,Interior Light,LED Light Type,Refrigerator Light</b>
Freezer Capacity	<b>6.5 cu.ft.</b>	Freezer Features	<b>Adjustable Temperature Control Ice Maker 24.4 inch width 6 gallon bottle frames silver interior black stainless</b>

# HRF3602 / HRF3602BS

**Product Description: 36-inch 4-door French Door Refrigerator with Recessed Handle in Stainless Steel (HRF3602) or Black Stainless Steel (HRF3602BS)**



Dimension (in)	W 35.8 X H 69.9 X D 28.7
Capacity (cu. ft.)	22.5 (R:16, F:6.5)
Climate	T
Energy	E-Star
Ice-maker	Automatic
Ice capacity	4.0 lbs./24h
Loading	48 pcs/ 40 HQ
Display	Digital
Gallon size	6 gallon bins
Lighting	LED (Top and sides)
C/D	24inch
Noise	42dB
ADA design	Yes
Cooling system	Single
Humidity control	Yes
MAP Price	\$2199 (HRF3602) / \$2299 (HRF3602BS)

## Compared to HRF3601F

**24.4 inches Depth, designed to meet the most efficient requirement for customer's cabinet**

**E-Star Energy with R600a Refrigeration**

**Enlarged refrigeration storage space**

**New Drawer Design with more space**

**Black Stainless Steel Available**

**Recessed Handle Design**

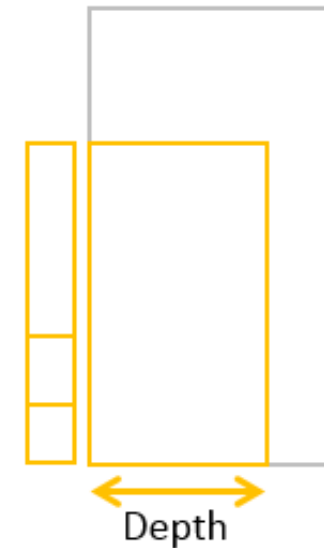

**Package Dimension (in):  
38.6 \* 31.5 \* 73.8**

# HRF3602 / HRF3602BS



**Large Door Bin Cabinets providing additional storage with convenience for customers**



# Model# **HRF3603F**

## Thor Kitchen 36-inch 4-door cross-gate Refrigerator with Recessed Handle

Refrigerator Size	<b>21cu.ft(14.2+3.9+3, 9)</b>	Number of Doors	<b>4</b>
Product Width(in)	<b>35.9</b>	Number of Shelves	<b>2</b>
Product Depth(in)	<b>30.6</b>	Number of Freezer Baskets/Bins	<b>6</b>
Product Height(in)	<b>71.3</b>	Refrigerator Shelf Material	<b>Glass</b>
Depth Excluding Handles(in)	<b>30.6</b>	Freezer Bin/Shelf Material	<b>Plastic</b>
Depth Including Handles	<b>30.6</b>	Color/Finish	<b>Inox looking</b>
Depth without Door	<b>26inch</b>	Gross Weight(lbs.)	<b>308.5</b>
Depth with Door Open 90 Degrees	<b>44.5inch</b>	Net Weight(lbs.)	<b>275.5</b>
Height to Top of Door Hinge	<b>71.3inch</b>	Certifications	<b>UL</b>
Height to Top of Refrigerator	<b>70.5inch</b>	Refrigerator Features	<b>No frost, Multi Airflow, Recessed handle, LED light, Full-width adjustable shelf, French pantry, XXL door balcony, Organized drawers, Electronical touch control</b>
Refrigerator Type	<b>Cross door No frost</b>		
Refrigerator Capacity	<b>14.2 cu. ft.</b>	Freezer Features	<b>Automatic icemaker in Freezer, Soft freeze compartment</b>
Freezer Capacity	<b>3.9+3.9 cu.ft.</b>		
Counter Depth?	<b>No</b>	Ice maker?	<b>Yes</b>
Shelf material?	<b>Glass</b>	Water Filter?	<b>No</b>
Water Dispenser?	<b>No</b>	Loading Information	<b>28/40HQ</b>



### Features:

- Four Cross-Gate; Defrost Function;
- US DOE Certification; recessed handle;
- Imitating Stainless Steel Panel; LED light design;
- Semi-Auto Icemaker; Inverted Compressor;
- Electronic Control Temperature sensor



A close-up, low-angle shot of the control panel of a Thor Kitchen outdoor appliance, likely a grill or smoker. The panel is black and features a row of seven large, black, textured knobs. The knobs are arranged from left to right, with the first knob on the far left and the last knob on the far right. The knobs are illuminated from below by a row of small, blue LED lights. The knobs have various settings and labels: the first knob has a scale from 300 to 450; the second knob has 'LOW' and 'SIM' labels; the third knob has 'LOW' and 'SIM' labels; the fourth knob has 'LOW' and 'SIM' labels; the fifth knob has 'LOW' and 'SIM' labels; the sixth knob has 'LOW' and 'SIM' labels; and the seventh knob has 'LOW' and 'SIM' labels. Below the knobs are several small, white icons: a power button, a light button, a convection fan button, and a temperature control button. The temperature control button has a scale from 300 to 450. The light and convection fan buttons are circular and have a blue ring around them. The text 'Light' and 'Convection Fan' is printed below the buttons. The overall lighting is dramatic, with the blue LEDs providing a strong contrast against the black panel.

## Thor Kitchen Outdoor Appliances and Tool Cabinets



Light  
Convection  
Fan

# Model# **HPO01SS** Outdoor Pizza Oven

## Spec:

- Carton Size: 33.46"W \* 33.46"D \* 23.62"H
- G.W.:218.3 Lbs. N.W.:178.6 Lbs.
- Wooden frame size:35.03 "W \* 35.03 "D \* 27.56"H
- 1 Year Limited Warranty on Parts
- UPC# 6926697001011

## Features:

- Wood Burning Design, Firebricks included
- Stainless Steel Arch and Cart (SS#430)
- Solid Weld Construction with Doors and Wheels
- Must be used with the cart
- Temperatures of 500-700 Degrees with built-in Thermometer
- Dimension: 32.3"W \*28.75"D \* 47.25"H
- Cooking Area: 0.48m<sup>2</sup> (25.2" × 29.5")

## Accessories available

- Brush, Pizza Cutter, Pizza Peel and Pizza/Pie Server







**THOR**  
K I T C H E N<sup>®</sup>

**Pro-Style Modular  
Outdoor Kitchen Suite**





## THOR Kitchen Pro-Style Modular Outdoor Kitchen Prep Station

- 2 storage drawer
- Bottom storage cabinet
- Bottle opener
- Storage tray



## THOR Kitchen Pro-Style 31 inch 4-Burner Built-in Propane Gas Island Grill in 304 Stainless Steel with Infrared Rotisserie Burner

- 4 x 12,000 BTU tube burner
- 1 x 10,000 BTU Infrared Rotisserie Burner
- LED Lights for Knobs
- Halogen light inside BBQ



### **THOR Kitchen Pro Style Modular Outdoor Kitchen Propane Gas 2 burner Griddle Module**

- Include a stainless steel lid
- 2 x 10,000 burner
- 2 x storage drawer



### **THOR Kitchen Pro-Style Modular Outdoor Kitchen Wood Burning Pizza Oven Module**

- Classic wood burning oven
- Ceramic pizza stone
- Not just for pizza
- Storage tray
- Extra large bottom storage cabinet



## **THOR Kitchen Pro Style Modular Outdoor Kitchen Bar Center**

- Storage tray
- Bottle opener
- Storage cabinet
- Kitchen sink



## THOR Kitchen Pro Style Modular Outdoor Kitchen Refrigerator Cabinet Module

- Provide outdoor appliances with a flush built-in look
- Provide additional prepping space



### HRF2401U

- Soft close Drawer
- White LED light
- Pro handle
- 304 ss drawer panel
- ETL listed for outdoor use



### TWC2401DO

- Dual-zone design
- 46 bottle capacity
- Blue LED light
- Door alarm
- Security lock
- Low-E coated glass
- 304 ss drawer panel
- ETL listed for outdoor use